

**ITAL SLAB**



**COLLECTION**

MADE IN ITALY



# Leave a mark

## Excellence and Italian Design for Your Spaces

Our tiles represent the authentic Made in Italy, a perfect combination of craftsmanship, innovation and style. Each collection is designed to enhance environments with high quality materials, refined finishes and cutting-edge aesthetic solutions. From marble-effect surfaces to nature-inspired textures, from contemporary tones to classic reinterpretations, our range offers versatility, durability and timeless beauty. Perfect for indoor and outdoor, our tiles are ideal to create unique, cozy and sophisticated spaces.

## Eccellenza e Design Italiano per i Tuoi Spazi

Le nostre piastrelle rappresentano l'autentico Made in Italy, un connubio perfetto tra artigianalità, innovazione e stile. Ogni collezione è progettata per valorizzare gli ambienti con materiali di alta qualità, finiture raffinate e soluzioni estetiche all'avanguardia. Dalle superfici effetto marmo alle texture ispirate alla natura, dai toni contemporanei alle reinterpretazioni classiche, la nostra gamma offre versatilità, resistenza e bellezza senza tempo. Perfette per interni ed esterni, le nostre piastrelle sono ideali per creare spazi unici, accoglienti e sofisticati.



# Technology

Innovation and advanced research at the service of architecture and interior design. Italslab are the outcome of latest generation technology, perfected and customised in a new factory built solely for their manufacture.

Innovazione e ricerca avanzata sono al servizio dell'architettura e dell'interior design. Italslab è il risultato di una tecnologia di ultima concezione, raffinata e customizzata in una fabbrica completamente nuova dedicata esclusivamente alla loro produzione.

# A GREENER WORLD



**MENO CONSUMO** - LESS CONSUMPTION  
**MENO EMISSIONI** - FEWER EMISSION  
**MENO COSTI** - LOWER COSTS  
**ZERO FONDAZIONI** - ZERO FOUNDATION WORK  
**BASSA RUMOROSITÀ** - LOW NOISE  
**RIDUZIONE DEGLI SCARTI CON RICLABILITÀ DEL 100%**  
LESS SCRAP WITH 100% RECYCLABILITY

## ITALSLAB

Production sustainability is a key concept to ensure balanced economic development that respects the environment and natural resources. This approach aims to reconcile industrial growth with ecosystem protection, reducing the negative impacts of production activities.

ITALSLAB slabs are a sustainable choice for coatings and flooring due to their durability, the natural raw materials used in production and the possibility of recycling.



La sostenibilità produttiva è un concetto chiave per garantire uno sviluppo economico equilibrato, rispettoso dell'ambiente e delle risorse naturali. Questo approccio mira a conciliare la crescita industriale con la tutela dell'ecosistema, riducendo gli impatti negativi delle attività produttive.

Le lastre di ITALSLAB rappresentano una scelta sostenibile per rivestimenti e pavimentazioni grazie alla loro durabilità, alle materie prime naturali impiegate nella produzione e alla possibilità di riciclo.

# PAGE INDEX

ITAL SLAB

Marble	Page	Stone	Page
Wild Galaxy	20	Coliseum Avorio	44
Giallo Siena	22	Coliseum Noce	45
Arabescato Firenze	23	Coliseum Beige	46
Silver River	24	Stone Contact Antracite	50
Grigio Portasanta	25	Stone Contact Grigio	51
Moonstone	26	Stone Contact Beige	52
Dover	27	Stone Contact Avorio	53
Ethereal Quartz	28	Yacht Cross Taupe	56
Cava Taj	29	Yacht Cross Bianco	57
Camouflage Greige	30	Yacht Cross Beige	58
Camouflage Silver	31	Yacht Vein Taupe	60
Ceppo Classic Gold	32	Yacht Vein Bianco	61
Ceppo Classic Grey	33	Yacht Vein Beige	62
Onyx Jewel	34		
Mirable	35	Cement	Page
Cava Caldia	36	Route 66 Asphalt	66
Cava Serafini	37	Route 66 Burgundy	67
Cava Vermont	38	Route 66 Ivory	68
Cava Gold	39	Route 66 Sage	69
Chateaux d'Argillers	42	Route 66 Silver	70
		Route 66 Taupe	71
		Solid Colors	Page
		Bianco Extra	74
		Nero Extra	75

# INDEX

ITAL SLAB

Porcelain Stoneware

Size	Thickness	Finish
160x320 cm 63"x126" in	6.5 mm 0.25" in	Lux
120x278 cm 48"x110" in	9 mm 0.25" in	Matt
120x120 cm 48"x48" in	12 mm 0.47" in	Honed
60x120 cm 24"x48" in	20 mm 0.47" in	5D Tech
		Structured
		Leather Structured

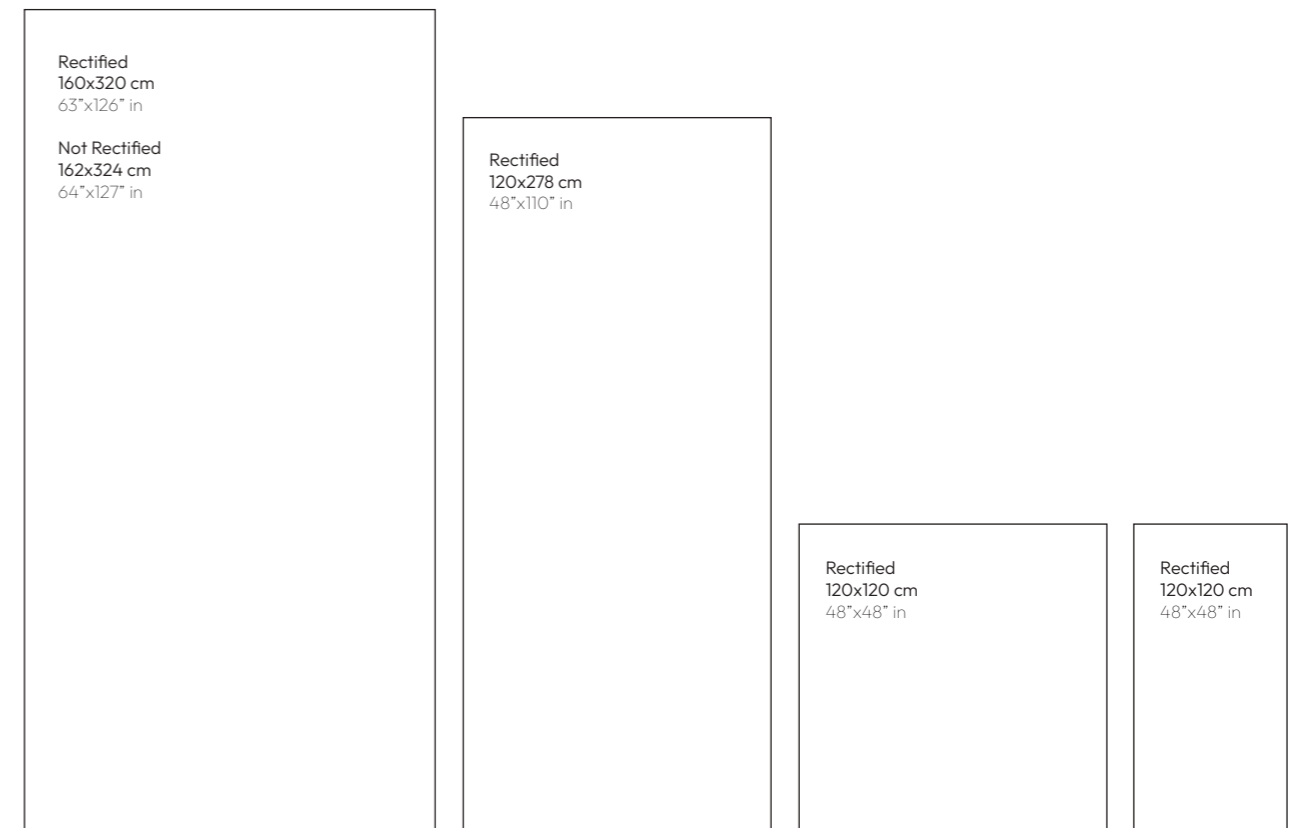

SIZES: 80x80 | 80x160 | 60x60 | 30x60 - on special projects under request

# USES

Porcelain stoneware combines strength and elegance, resisting time, stains, and heat—where marble may fade, it endures, a timeless beauty with effortless grace.

## UTILIZZA I COLORI

Il grès porcellanato unisce forza ed eleganza, resiste al tempo, macchie e calore dove il marmo può sbiadire, resiste una bellezza senza tempo con grazia senza sforzo.



## Tables



## Counter Top

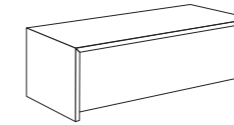

## Bathroom Top



## Washbasin

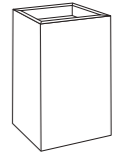

## Shelf

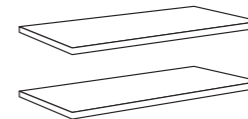

## Door

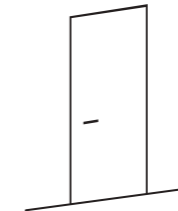

## Planter



## Seats



- **Exceptional durability:** resistant to impacts, scratches, and daily wear, preserving its look over time.
- **Non-absorbent:** does not absorb liquids or stains, making it ideal for surfaces in contact with water, food, or chemicals.
- **Color stability:** colors remain unchanged over time, even when exposed to direct sunlight.
- **Thin profiles:** allows for lightweight cladding without weighing down structures — perfect for furniture and accessories.
- **Aesthetic versatility:** available in a wide range of finishes that realistically replicate stone, marble, concrete, or wood.



# COLORS

## Porcelain Stoneware

Wild Galaxy



Giallo Siena



Arabescato Firenze



Silver River



Moonstone



Dover



Ethereal Quartz



Cava Taj



Camouflage Greige



Camouflage Silver



Grigio Portasanta



Ceppo Classig Gold



Ceppo Classig Grey



Onyx Jewel



Mirabile



Cava Caldia



Cava Serafini

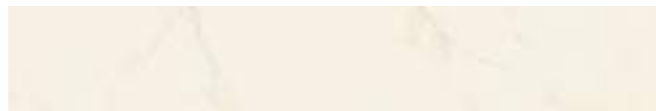

Cava Vermont



Cava Gold



Chateaux d'Argillers



Coliseum Avorio



Coliseum Noce



Coliseum Beige



Stone Contact Antracite



Stone Contact Grigio



Stone Contact Beige



Stone Contact Avorio



Yacht Cross Taupe

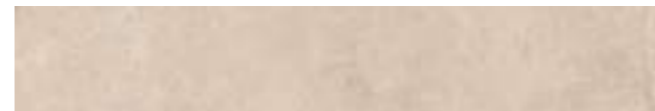

Yacht Cross Bianco



Yacht Cross Beige



Yacht Vein Taupe



Yacht Vein Bianco



Yacht Vein Beige



Route 66 Asphalt



Route 66 Burgundy



Route 66 Ivory



Route 66 Sage



Route 66 Silver



Route 66 Taupe



Bianco Extra

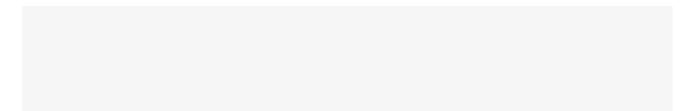

Nero Extra





floor: WILD GALAXY GOLD 120X120  
wall: WILD GALAXY 120X278 - furniture: WILD GALAXY 160X320



WILD GALAXY 160X320



floor: WILD GALAXY GOLD 120X120  
furniture: WILD GALAXI 160X320



floor: WILD GALAXY GOLD 120X120  
wall: WILD GALAXY 120X278



WILD GALAXY GREY 120X120



WILD GALAXY GREY 120X120

# WILD GALAXY

Porcelain Stoneware



## Bookmatch

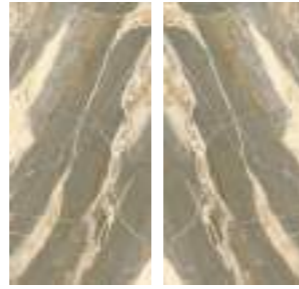

160x320 63"x126"

Size	Thickness	Finish
 160x320 cm 63"x126" in	6.5 mm 0.25" in	Lux Matt Honed
	12 mm 0.47" in	
	20 mm 0.78" in	

# WILD GALAXY

Porcelain Stoneware

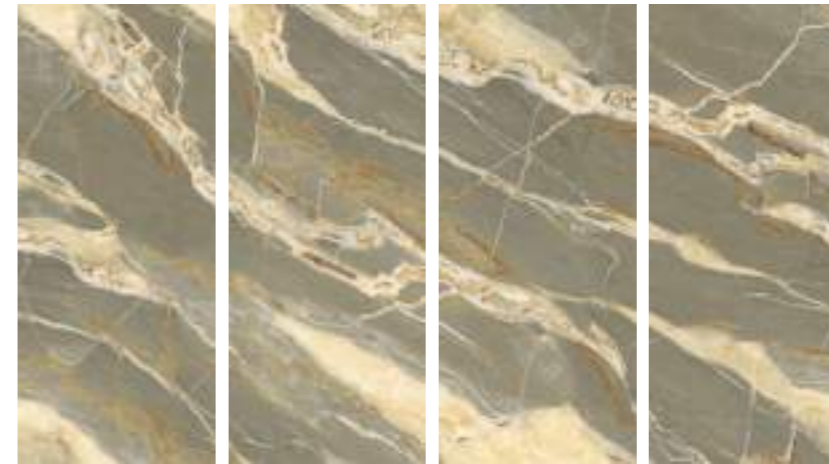

Size	Thickness	Finish
 120x278 cm 48"x110" in	6.5 mm 0.25" in	5D

# WILD GALAXY GOLD

Porcelain Stoneware



Size	Thickness	Finish
 120x120 cm 48"x48" in	9 mm 0.35" in	5D
	20 mm 0.78" in	

# WILD GALAXY GREY

Porcelain Stoneware



Size	Thickness	Finish
 60x120 cm 24"x48" in	9 mm 0.35" in	5D
	20 mm 0.78" in	

# GIALLO SIENA



Porcelain Stoneware



## Bookmatch



160x320 63"x126"

Size	Thickness	Finish
 160x320 cm 63"x126" in	6.5 mm 0.25" in	Lux
	12 mm 0.47" in	Matt
	20 mm 0.78" in	Honed Structured
 120x278 cm 48"x110" in	6.5 mm 0.25" in	Lux Matt Honed Structured

# ARABESCATO FIRENZE

Porcelain Stoneware



## Bookmatch

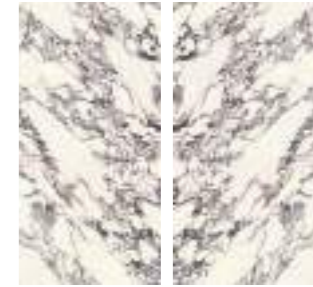

160x320 63"x126"

Size	Thickness	Finish
 160x320 cm 63"x126" in	6.5 mm 0.25" in	Lux
	12 mm 0.47" in	Matt
	20 mm 0.78" in	Honed

# SILVER RIVER





Porcelain Stoneware



## Bookmatch



160x320 63"x126"

Size	Thickness	Finish
 160x320 cm 63"x126" in	6.5 mm 0.25" in	Lux Matt Honed
	12 mm 0.47" in	
	20 mm 0.78" in	
 120x278 cm 48"x110" in	6.5 mm 0.25" in	5D
 120x120 cm 48"x48" in	9 mm 0.35" in	5D
 60x120 cm 24"x48" in	9 mm 0.35" in	5D

# GRIGIO PORTASANTA





Porcelain Stoneware

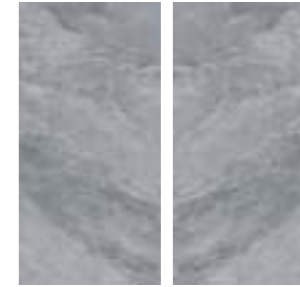

## Bookmatch



160x320 63"x126"

Size	Thickness	Finish
 160x320 cm 63"x126" in	6.5 mm 0.25" in	Lux Matt Honed
	12 mm 0.47" in	
	20 mm 0.78" in	
 120x278 cm 48"x110" in	6.5 mm 0.25" in	Lux Matt Honed
 120x120 cm 48"x48" in	9 mm 0.35" in	Lux Matt
 60x120 cm 24"x48" in	9 mm 0.35" in	Lux Matt

# MOONSTONE





Porcelain Stoneware

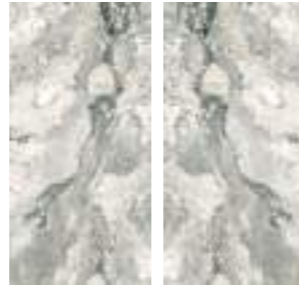

## Bookmatch



160x320 63"x126"

Size	Thickness	Finish
 160x320 cm 63"x126" in	6.5 mm 0.25" in	Lux Matt
	12 mm 0.47" in	Honed Structured
	20 mm 0.78" in	Leather Structured
 120x278 cm 48"x110" in	6.5 mm 0.25" in	5D Structured
		Leather Structured
 120x120 cm 48"x48" in	9 mm 0.35" in	5D Structured
	20 mm 0.78" in	Leather Structured
 60x120 cm 24"x48" in	9 mm 0.35" in	5D Structured
	20 mm 0.78" in	Leather Structured

# DOVER

Porcelain Stoneware

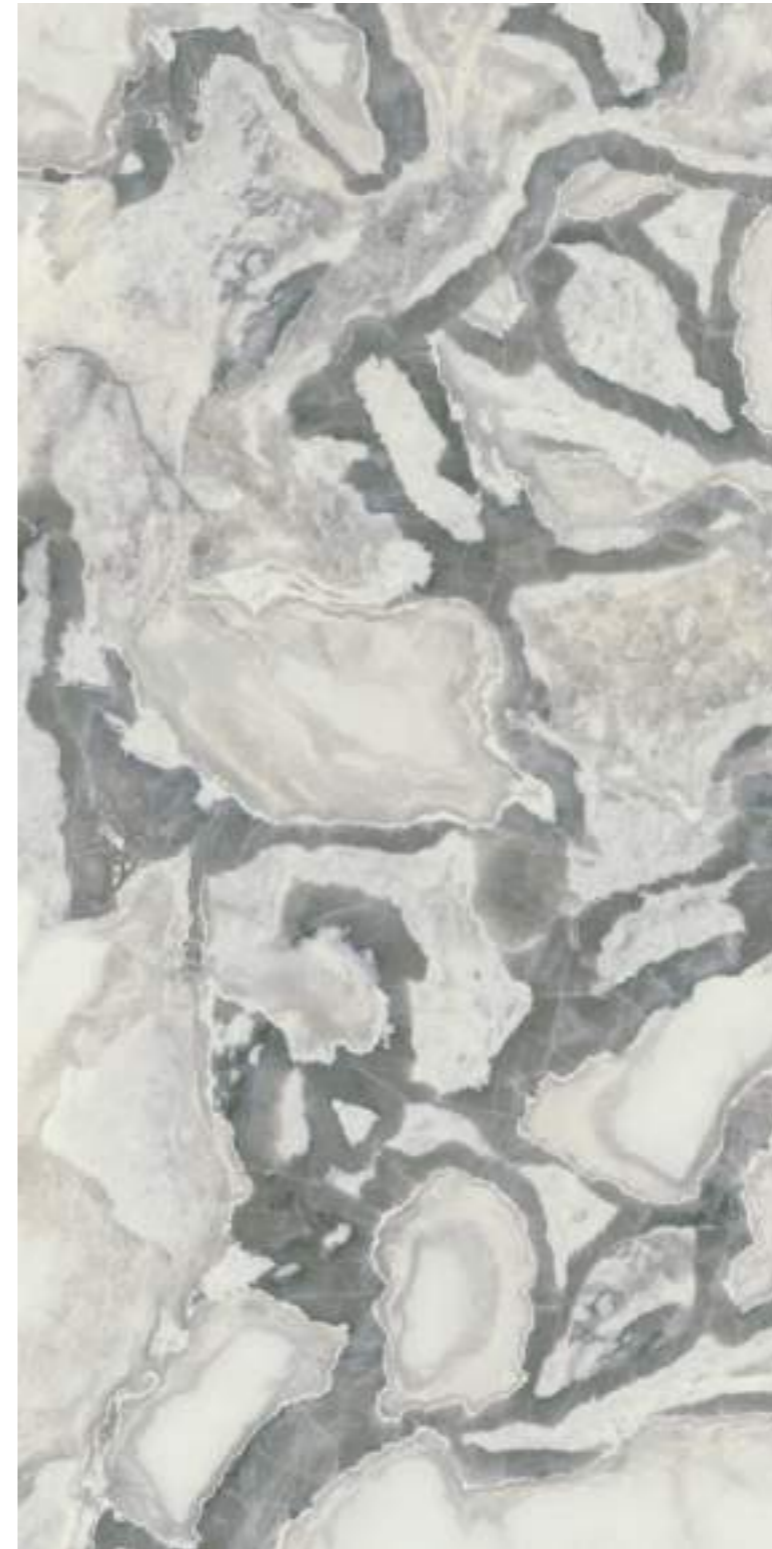

## Bookmatch

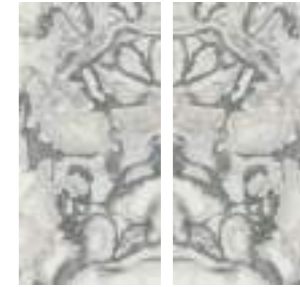

160x320 63"x126"

Size	Thickness	Finish
 160x320 cm 63"x126" in	6.5 mm 0.25" in	Lux Matt
	12 mm 0.47" in	Honed
	20 mm 0.78" in	Leather Structured

# ETHEREAL QUARTZ





Porcelain Stoneware



## Bookmatch



160x320 63"x126"

Size	Thickness	Finish
 160x320 cm 63"x126" in	6.5 mm 0.25" in	Lux
	12 mm 0.47" in	Matt
	20 mm 0.78" in	Honed
 120x278 cm 48"x110" in	6.5 mm 0.25" in	Lux
		Matt Honed
 120x120 cm 48"x48" in	9 mm 0.35" in	Lux Matt
 60x120 cm 24"x48" in	9 mm 0.35" in	Lux Matt

# CAVA TAJ





Porcelain Stoneware



## Bookmatch



160x320 63"x126"

Size	Thickness	Finish
 160x320 cm 63"x126" in	6.5 mm 0.25" in	Lux
	12 mm 0.47" in	Matt
	20 mm 0.78" in	Honed
 120x278 cm 48"x110" in	6.5 mm 0.25" in	Lux
		Matt Honed
 120x120 cm 48"x48" in	9 mm 0.35" in	Lux Matt
 60x120 cm 24"x48" in	9 mm 0.35" in	Lux Matt

# CAMOUFLAGE GREIGE

Porcelain Stoneware



## Bookmatch



160x320 63"x126"

Size	Thickness	Finish
 160x320 cm 63"x126" in	6.5 mm 0.25" in	Lux Matt Honed
	12 mm 0.47" in	
	20 mm 0.78" in	

# CAMOUFLAGE SILVER

Porcelain Stoneware



## Bookmatch

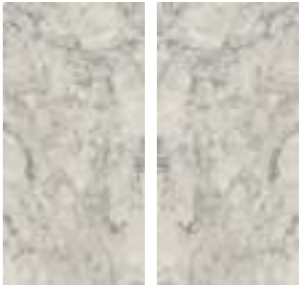





160x320 63"x126"

Size	Thickness	Finish
 160x320 cm 63"x126" in	6.5 mm 0.25" in	Lux Matt Honed
	12 mm 0.47" in	
	20 mm 0.78" in	

# CEPPO CLASSIC GOLD

Porcelain Stoneware







Size	Thickness	Finish
 160x320 cm 63"x126" in	6.5 mm 0.25" in	Lux Matt
	12 mm 0.47" in	Honed Structured
	20 mm 0.78" in	Leather Structured
 120x278 cm 48"x110" in	6.5 mm 0.25" in	5D Structured
		Leather Structured
 120x120 cm 48"x48" in	9 mm 0.35" in	5D Structured
	20 mm 0.78" in	Leather Structured
 60x120 cm 24"x48" in	9 mm 0.35" in	5D Structured
	20 mm 0.78" in	Leather Structured

# CEPPO CLASSIC GREY

Porcelain Stoneware



Size	Thickness	Finish
 160x320 cm 63"x126" in	6.5 mm 0.25" in	Lux Matt
	12 mm 0.47" in	Honed Structured
	20 mm 0.78" in	Leather Structured
 120x278 cm 48"x110" in	6.5 mm 0.25" in	5D Structured
		Leather Structured
 120x120 cm 48"x48" in	9 mm 0.35" in	5D Structured
	20 mm 0.78" in	Leather Structured
 60x120 cm 24"x48" in	9 mm 0.35" in	5D Structured
	20 mm 0.78" in	Leather Structured

# ONYX JEWEL





Porcelain Stoneware



## Bookmatch



160x320 63"x126"

Size	Thickness	Finish
 160x320 cm 63"x126" in	6.5 mm 0.25" in	Lux Matt
	12 mm 0.47" in	Honed
	20 mm 0.78" in	
 120x278 cm 48"x110" in	6.5 mm 0.25" in	Lux Matt Honed
 120x120 cm 48"x48" in	9 mm 0.35" in	Lux Matt
 60x120 cm 24"x48" in	9 mm 0.35" in	Lux Matt

# MIRABLE



Porcelain Stoneware



## Bookmatch

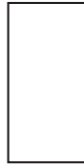
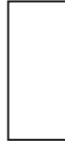

160x320 63"x126"

Size	Thickness	Finish
 160x320 cm 63"x126" in	6.5 mm 0.25" in	Lux Matt Honed
	12 mm 0.47" in	Structured
	20 mm 0.78" in	Leather Structured
 120x278 cm 48"x110" in	6.5 mm 0.25" in	Lux Matt Honed
		Structured
 120x120 cm 48"x48" in		
 60x120 cm 24"x48" in		

# CAVA CALDIA





Porcelain Stoneware



## Bookmatch



160x320 63"x126"

Size	Thickness	Finish
 160x320 cm 63"x126" in	6.5 mm 0.25" in	Lux Matt
	12 mm 0.47" in	Honed Structured
	20 mm 0.78" in	Leather Structured
 120x278 cm 48"x110" in	6.5 mm 0.25" in	Lux Matt Honed Structured
		Leather Structured
 120x120 cm 48"x48" in	9 mm 0.35" in	Lux Matt Structured Leather Structured
 60x120 cm 24"x48" in	9 mm 0.35" in	Lux Matt Structured Leather Structured

# CAVA SERAFINI





Porcelain Stoneware



## Bookmatch



160x320 63"x126"

Size	Thickness	Finish
 160x320 cm 63"x126" in	6.5 mm 0.25" in	Lux Matt
	12 mm 0.47" in	Honed Structured
	20 mm 0.78" in	Leather Structured
 120x278 cm 48"x110" in	6.5 mm 0.25" in	Lux Matt Honed Structured
		Leather Structured
 120x120 cm 48"x48" in	9 mm 0.35" in	Lux Matt Structured Leather Structured
 60x120 cm 24"x48" in	9 mm 0.35" in	Lux Matt Structured Leather Structured

# CAVA VERMONT





Porcelain Stoneware



## Bookmatch



160x320 63"x126"

Size	Thickness	Finish
 160x320 cm 63"x126" in	6.5 mm 0.25" in	Lux Matt
	12 mm 0.47" in	Honed
	20 mm 0.78" in	
 120x278 cm 48"x110" in	6.5 mm 0.25" in	Lux Matt Honed
 120x120 cm 48"x48" in	9 mm 0.35" in	Lux Matt
 60x120 cm 24"x48" in	9 mm 0.35" in	Lux Matt

# CAVA GOLD





Porcelain Stoneware



## Bookmatch



160x320 63"x126"

Size	Thickness	Finish
 160x320 cm 63"x126" in	6.5 mm 0.25" in	Lux Matt
	12 mm 0.47" in	Honed Structured
	20 mm 0.78" in	Leather Structured
 120x278 cm 48"x110" in	6.5 mm 0.25" in	5D Structured
		Leather Structured
 120x120 cm 48"x48" in	9 mm 0.35" in	5D Structured
		Leather Structured
 60x120 cm 24"x48" in	9 mm 0.35" in	5D Structured
		Leather Structured



# CHATEAUX D'ARGILLERS





Porcelain Stoneware



## Bookmatch



160x320 63"x126"

Size	Thickness	Finish
 160x320 cm 63"x126" in	6.5 mm 0.25" in 12 mm 0.47" in 20 mm 0.78" in	Lux Matt Honed
 120x278 cm 48"x110" in	6.5 mm 0.25" in	Lux Matt Honed
 120x120 cm 48"x48" in	9 mm 0.35" in	Lux Matt
 60x120 cm 24"x48" in	9 mm 0.35" in	Lux Matt







CHATEAUX D'ARGILLERS 160x320

# COLISEUM AVORIO

Porcelain Stoneware







Size	Thickness	Finish
 160x320 cm 63"x126" in	6.5 mm 0.25" in	Matt
	12 mm 0.47" in	
	20 mm 0.78" in	
 120x278 cm 48"x110" in	6.5 mm 0.25" in	5D Matt
 120x120 cm 48"x48" in	9 mm 0.35" in	5D Matt
 60x120 cm 24"x48" in	9 mm 0.35" in	5D Matt

# COLISEUM NOCE

Porcelain Stoneware







Size	Thickness	Finish
 160x320 cm 63"x126" in	6.5 mm 0.25" in	Matt
	12 mm 0.47" in	
	20 mm 0.78" in	
 120x278 cm 48"x110" in	6.5 mm 0.25" in	5D Matt
 120x120 cm 48"x48" in	9 mm 0.35" in	5D Matt
 60x120 cm 24"x48" in	9 mm 0.35" in	5D Matt

# COLISEUM BEIGE

Porcelain Stoneware



Size	Thickness	Finish
 160x320 cm 63"x126" in	6.5 mm 0.25" in	Matt
	12 mm 0.47" in	
	20 mm 0.78" in	
 120x278 cm 48"x110" in	6.5 mm 0.25" in	5D Matt
 120x120 cm 48"x48" in	9 mm 0.35" in	5D Matt
 60x120 cm 24"x48" in	9 mm 0.35" in	5D Matt



COLISEUM BEIGE 160x320



floor: STONE CONTACT AVORIO 160x320  
wall: STONE CONTACT ANTRACITE 160x320  
furniture: STONE CONTACT GRIGIO 160x320

# STONE CONTACT ANTRACITE

Porcelain Stoneware



Size                      Thickness      Finish

	160x320 cm 63"x126" in	6.5 mm 0.25" in 12 mm 0.47" in 20 mm 0.78" in	Matt
--	---------------------------	--	------

	120x278 cm 48"x110" in	6.5 mm 0.25" in	5D Matt
--	---------------------------	--------------------	------------

	120x120 cm 48"x48" in	9 mm 0.35" in	5D Matt
--	--------------------------	------------------	------------

	60x120 cm 24"x48" in	9 mm 0.35" in	5D Matt
--	-------------------------	------------------	------------

# STONE CONTACT GRIGIO

Porcelain Stoneware



Size                      Thickness      Finish

	160x320 cm 63"x126" in	6.5 mm 0.25" in 12 mm 0.47" in 20 mm 0.78" in	Matt
---	---------------------------	--	------

	120x278 cm 48"x110" in	6.5 mm 0.25" in	5D Matt
---	---------------------------	--------------------	------------





	120x120 cm 48"x48" in	9 mm 0.35" in	5D Matt
---	--------------------------	------------------	------------

	60x120 cm 24"x48" in	9 mm 0.35" in	5D Matt
---	-------------------------	------------------	------------

# STONE CONTACT BEIGE

Porcelain Stoneware







Size	Thickness	Finish
 160x320 cm 63"x126" in	6.5 mm 0.25" in	Matt
	12 mm 0.47" in	
	20 mm 0.78" in	
 120x278 cm 48"x110" in	6.5 mm 0.25" in	5D
		Matt
 120x120 cm 48"x48" in	9 mm 0.35" in	5D Matt
 60x120 cm 24"x48" in	9 mm 0.35" in	5D Matt

# STONE CONTACT AVORIO

Porcelain Stoneware



Size	Thickness	Finish
 160x320 cm 63"x126" in	6.5 mm 0.25" in	Matt
	12 mm 0.47" in	
	20 mm 0.78" in	
 120x278 cm 48"x110" in	6.5 mm 0.25" in	5D Matt
 120x120 cm 48"x48" in	9 mm 0.35" in	5D Matt
 60x120 cm 24"x48" in	9 mm 0.35" in	5D Matt



ELEVATORS ▶

floor: YACHT CROSS TAUPE 160x320  
wall: YACHT VEIN TAUPE/BIANCO 160x320  
furniture: YACHT CROSS TAUPE/BIANCO 160x320

# YACHT CROSS TAUPE

Porcelain Stoneware



Size	Thickness	Finish
------	-----------	--------

	160x320 cm 63"x126" in	6.5 mm 0.25" in	Matt
		12 mm 0.47" in	
		20 mm 0.78" in	

	120x278 cm 48"x110" in	6.5 mm 0.25" in	5D
			Matt

	120x120 cm 48"x48" in	9 mm 0.35" in	5D
			Matt

	60x120 cm 24"x48" in	9 mm 0.35" in	5D
			Matt

# YACHT CROSS BIANCO

Porcelain Stoneware

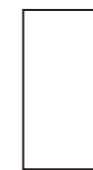

Size	Thickness	Finish
------	-----------	--------

	160x320 cm 63"x126" in	6.5 mm 0.25" in	Matt
		12 mm 0.47" in	
		20 mm 0.78" in	

	120x278 cm 48"x110" in	6.5 mm 0.25" in	5D
			Matt





	120x120 cm 48"x48" in	9 mm 0.35" in	5D
			Matt

	60x120 cm 24"x48" in	9 mm 0.35" in	5D
			Matt

# YACHT CROSS BEIGE

Porcelain Stoneware



Size	Thickness	Finish
 160x320 cm 63"x126" in	6.5 mm 0.25" in 12 mm 0.47" in 20 mm 0.78" in	Matt
 120x278 cm 48"x110" in	6.5 mm 0.25" in	5D Matt
 120x120 cm 48"x48" in	9 mm 0.35" in	5D Matt
 60x120 cm 24"x48" in	9 mm 0.35" in	5D Matt







YACHT CROSS BEIGE 160x320

# YACHT VEIN TAUPE

Porcelain Stoneware







Size	Thickness	Finish
 160x320 cm 63"x126" in	6.5 mm 0.25" in	Matt
	12 mm 0.47" in	
	20 mm 0.78" in	
 120x278 cm 48"x110" in	6.5 mm 0.25" in	5D
		Matt
 120x120 cm 48"x48" in	9 mm 0.35" in	5D
		Matt
 60x120 cm 24"x48" in	9 mm 0.35" in	5D
		Matt

# YACHT VEIN BIANCO

Porcelain Stoneware







Size	Thickness	Finish
 160x320 cm 63"x126" in	6.5 mm 0.25" in	Matt
	12 mm 0.47" in	
	20 mm 0.78" in	
 120x278 cm 48"x110" in	6.5 mm 0.25" in	5D
		Matt
 120x120 cm 48"x48" in	9 mm 0.35" in	5D
		Matt
 60x120 cm 24"x48" in	9 mm 0.35" in	5D
		Matt

# YACHT VEIN BEIGE

Porcelain Stoneware



Size	Thickness	Finish
 160x320 cm 63"x126" in	6.5 mm 0.25" in	Matt
	12 mm 0.47" in	
	20 mm 0.78" in	
 120x278 cm 48"x110" in	6.5 mm 0.25" in	5D Matt
 120x120 cm 48"x48" in	9 mm 0.35" in	5D Matt
 60x120 cm 24"x48" in	9 mm 0.35" in	5D Matt





floor: ROUTE 66 BURGUNDY 160x320  
wall: ROUTE 66 TAUPE 160x320  
furniture: ROUTE 66 TAUPE/BURGUNDY 160x320

# ROUTE 66 ASPHALT

Porcelain Stoneware



Size	Thickness	Finish
------	-----------	--------

	160x320 cm 63"x126" in	6.5 mm 0.25" in	Matt
		12 mm 0.47" in	
		20 mm 0.78" in	

	120x278 cm 48"x110" in	6.5 mm 0.25" in	5D
			Matt

	120x120 cm 48"x48" in	9 mm 0.35" in	5D
			Matt

	60x120 cm 24"x48" in	9 mm 0.35" in	5D
			Matt

# ROUTE 66 BURGUNDY

Porcelain Stoneware



Size	Thickness	Finish
------	-----------	--------

	160x320 cm 63"x126" in	6.5 mm 0.25" in	Matt	
				12 mm 0.47" in
				20 mm 0.78" in

	120x278 cm 48"x110" in	6.5 mm 0.25" in	5D
			Matt

	120x120 cm 48"x48" in	9 mm 0.35" in	5D
			Matt

	60x120 cm 24"x48" in	9 mm 0.35" in	5D
			Matt

# ROUTE 66 IVORY

Porcelain Stoneware

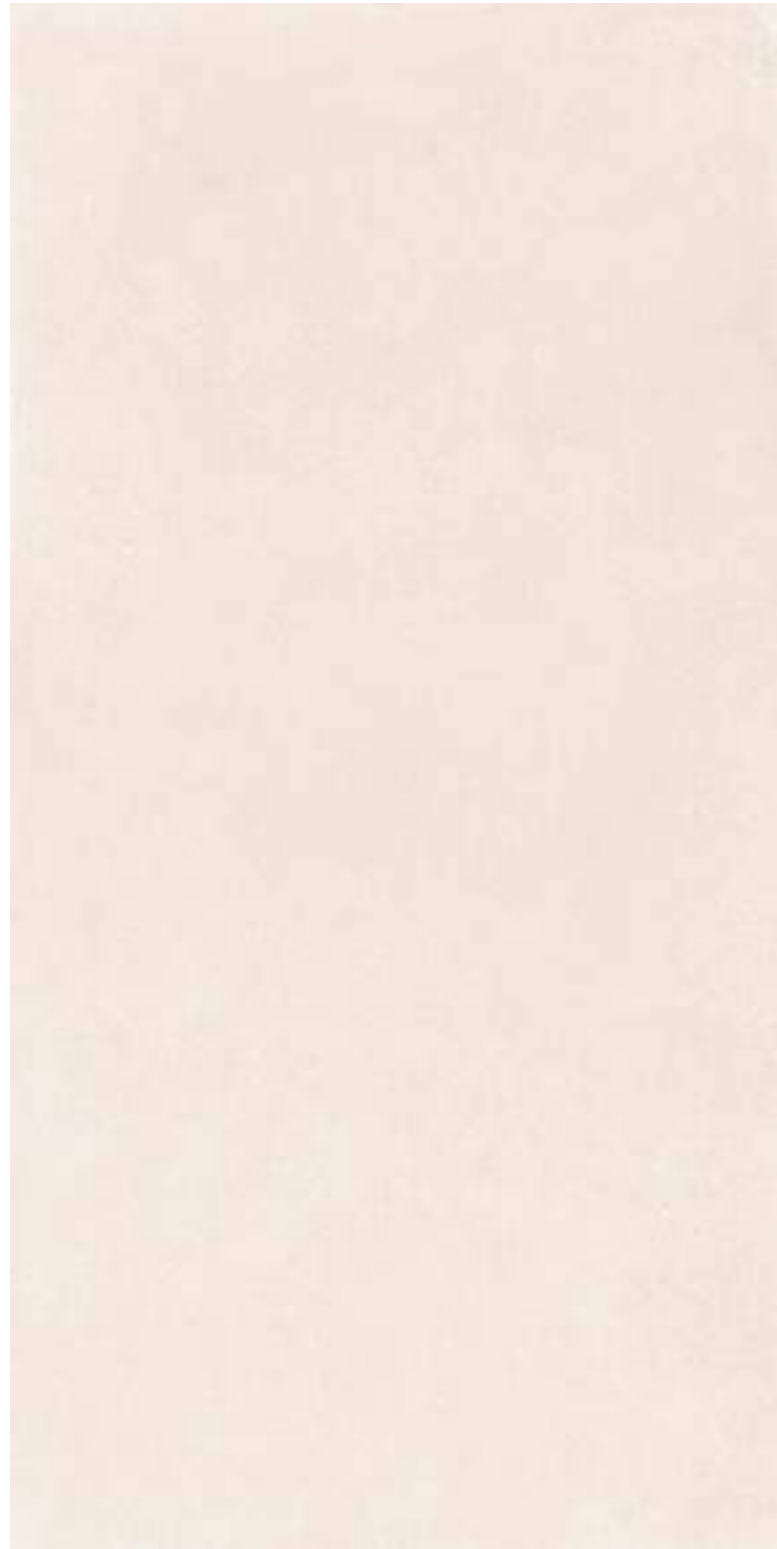

Size Thickness Finish

	160x320 cm 63"x126" in	6.5 mm 0.25" in	Matt
		12 mm 0.47" in	
		20 mm 0.78" in	

	120x278 cm 48"x110" in	6.5 mm 0.25" in	5D
			Matt

	120x120 cm 48"x48" in	9 mm 0.35" in	5D
			Matt

	60x120 cm 24"x48" in	9 mm 0.35" in	5D
			Matt

# ROUTE 66 SAGE

Porcelain Stoneware



Size Thickness Finish

	160x320 cm 63"x126" in	6.5 mm 0.25" in	Matt
		12 mm 0.47" in	
		20 mm 0.78" in	

	120x278 cm 48"x110" in	6.5 mm 0.25" in	5D
			Matt

	120x120 cm 48"x48" in	9 mm 0.35" in	5D
			Matt

	60x120 cm 24"x48" in	9 mm 0.35" in	5D
			Matt

# ROUTE 66 SILVER

Porcelain Stoneware



Size                      Thickness      Finish

	160x320 cm 63"x126" in	6.5 mm 0.25" in	Matt
		12 mm 0.47" in	
		20 mm 0.78" in	

	120x278 cm 48"x110" in	6.5 mm 0.25" in	5D
			Matt

	120x120 cm 48"x48" in	9 mm 0.35" in	5D
			Matt

	60x120 cm 24"x48" in	9 mm 0.35" in	5D
			Matt

# ROUTE 66 TAUPE

Porcelain Stoneware

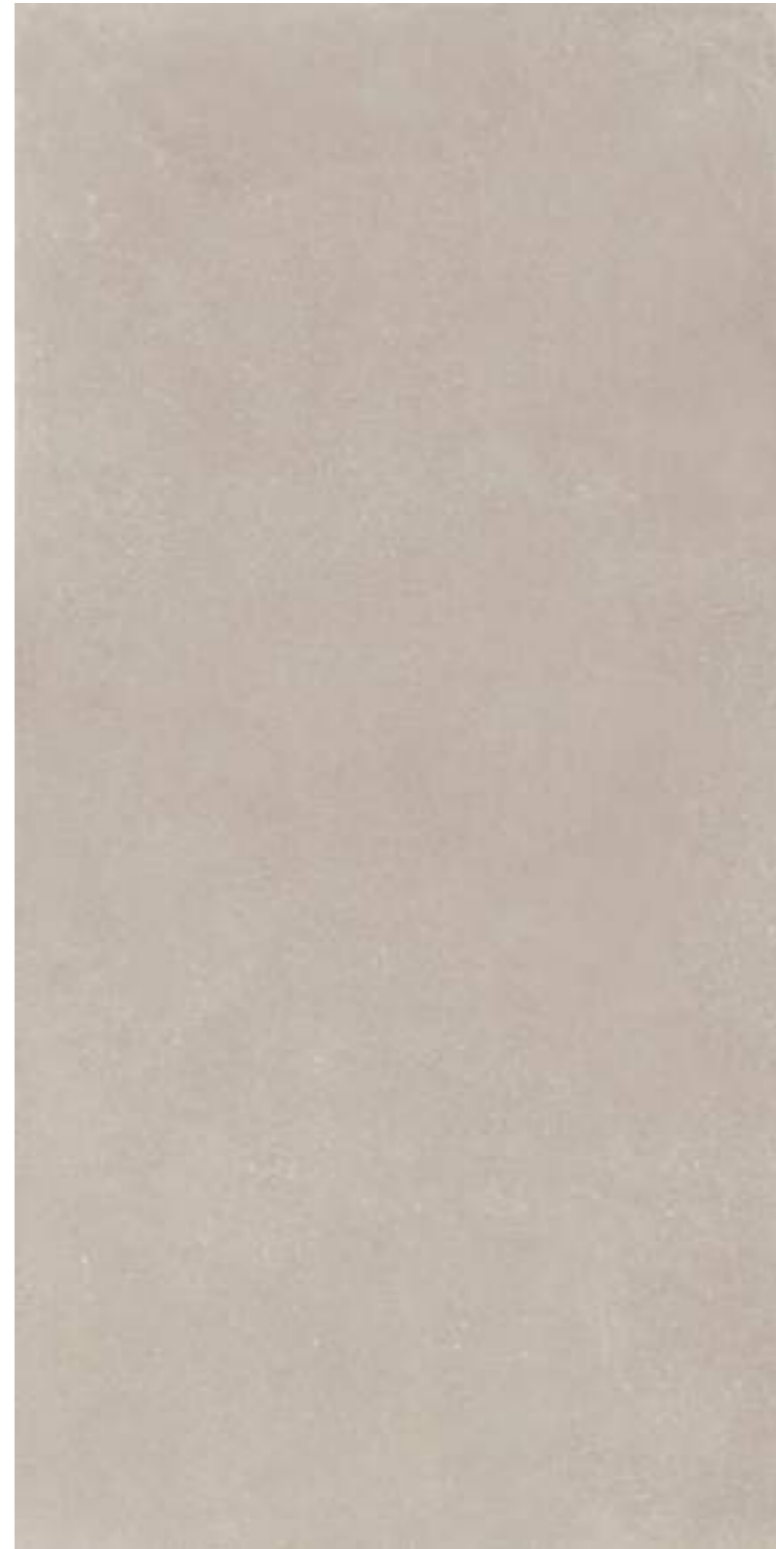

Size                      Thickness      Finish

	160x320 cm 63"x126" in	6.5 mm 0.25" in	Matt
		12 mm 0.47" in	
		20 mm 0.78" in	

	120x278 cm 48"x110" in	6.5 mm 0.25" in	5D
			Matt

	120x120 cm 48"x48" in	9 mm 0.35" in	5D
			Matt

	60x120 cm 24"x48" in	9 mm 0.35" in	5D
			Matt



ROUTE 66 SILVER 160x320



furniture: ROUTE 66 SAGE 160x320  
Floor: ROUTE 66 SILVER 160x320

# BIANCO EXTRA

Porcelain Stoneware

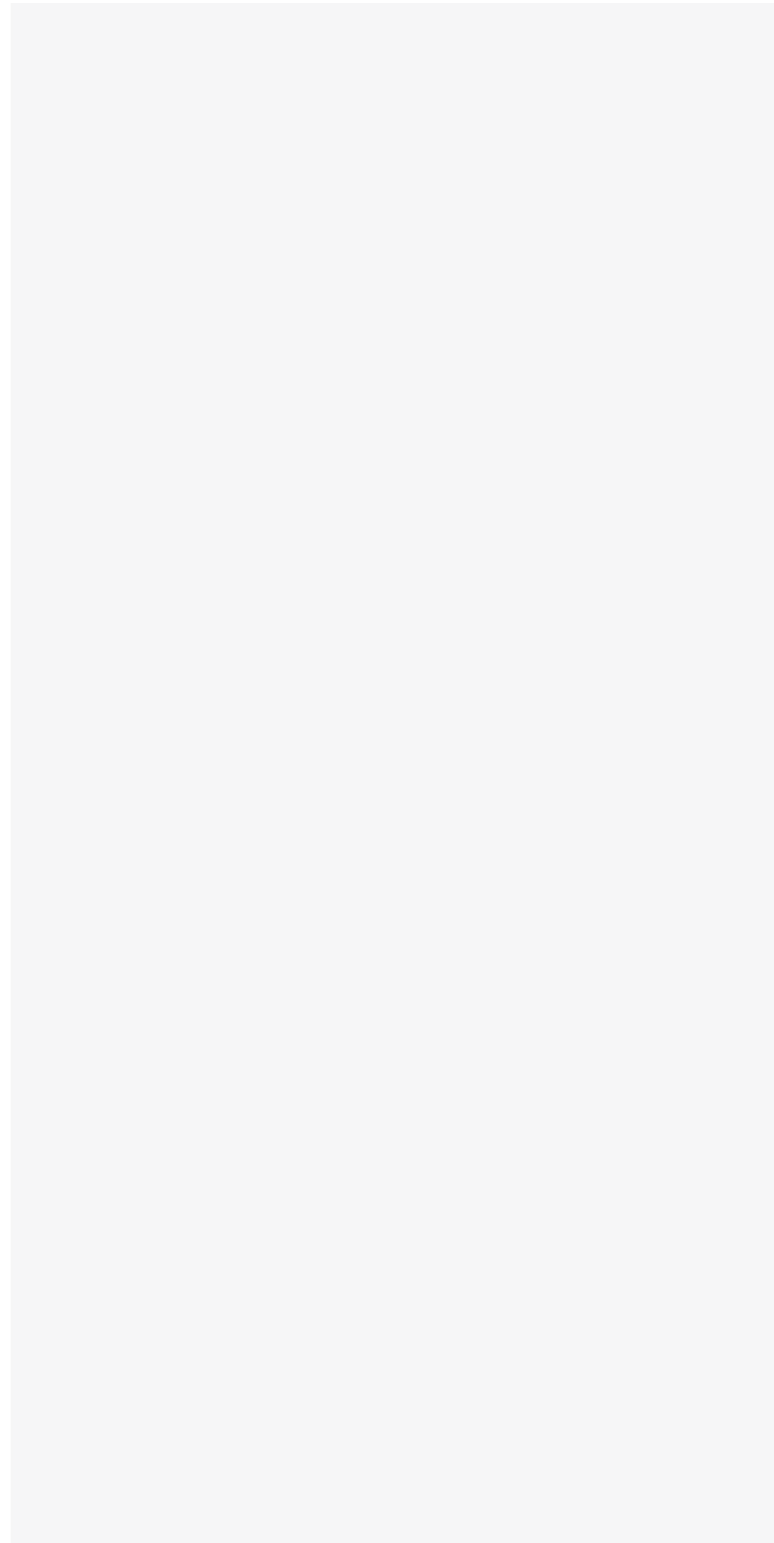

Size	Thickness	Finish
------	-----------	--------

	160x320 cm 63"x126" in	6.5 mm 0.25" in	Lux Matt
		12 mm 0.47" in	
		20 mm 0.78" in	

	120x278 cm 48"x110" in	6.5 mm 0.25" in	Lux Matt
--	---------------------------	--------------------	-------------

	120x120 cm 48"x48" in	9 mm 0.35" in	Lux Matt
--	--------------------------	------------------	-------------

	60x120 cm 24"x48" in	9 mm 0.35" in	Lux Matt
--	-------------------------	------------------	-------------

# NERO EXTRA

Porcelain Stoneware

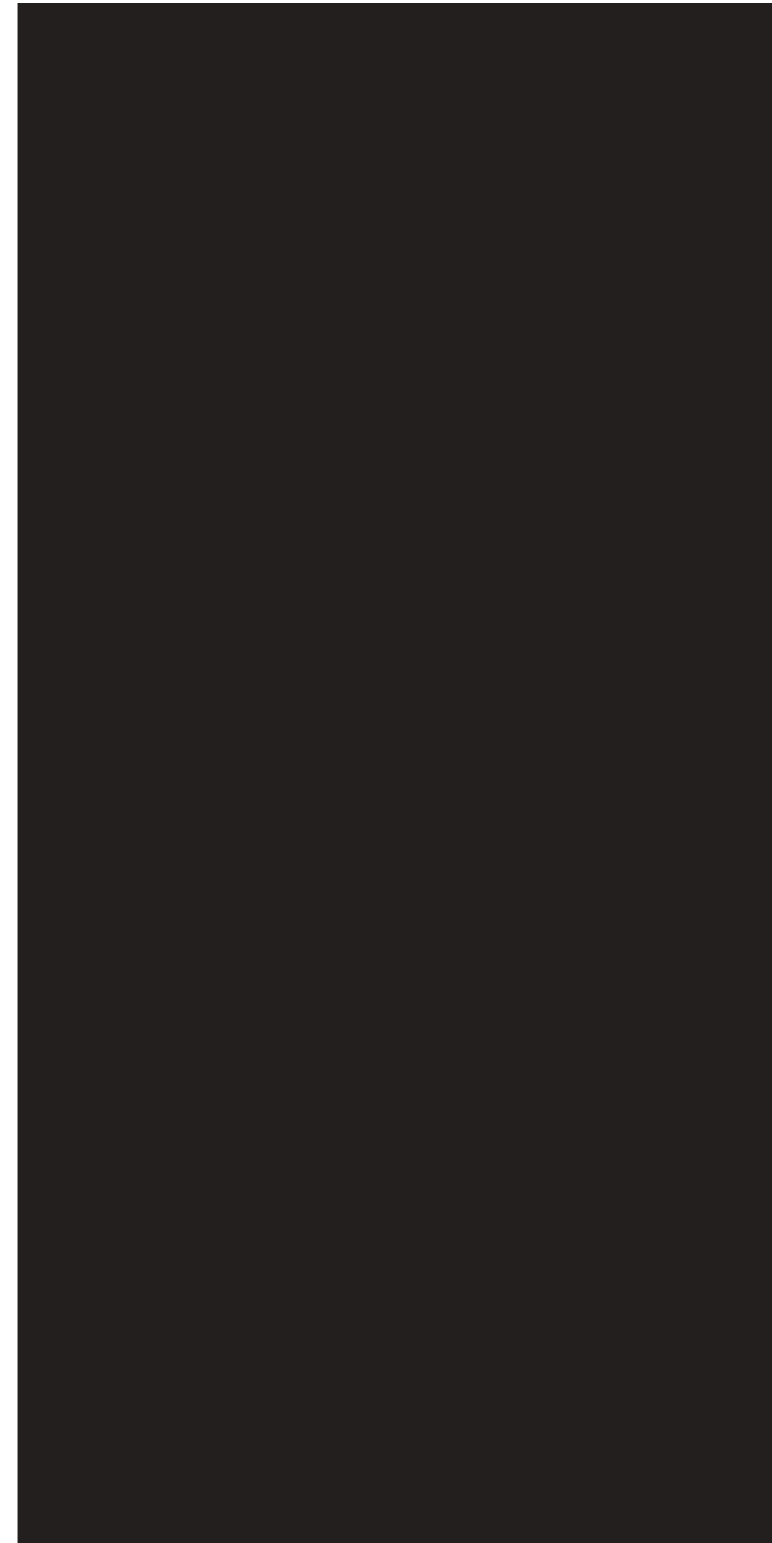

Size	Thickness	Finish
------	-----------	--------

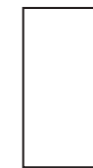
	160x320 cm 63"x126" in	6.5 mm 0.25" in	Matt
		12 mm 0.47" in	
		20 mm 0.78" in	

	120x278 cm 48"x110" in	6.5 mm 0.25" in	Matt
---	---------------------------	--------------------	------

	120x120 cm 48"x48" in	9 mm 0.35" in	Matt
---	--------------------------	------------------	------

	60x120 cm 24"x48" in	9 mm 0.35" in	Matt
---	-------------------------	------------------	------

## INDICAZIONI GENERALI PER LA MOVIMENTAZIONE, POSA E TAGLIO

### GENERAL INDICATIONS FOR HANDLING, LAYING AND CUTTING

Durante il disimballo delle lastre, è necessario prelevare dal cavalletto le lastre in modo alternato sui due lati, per mantenere e garantire la massima stabilità del carico.

Ove possibile si consiglia l'utilizzo di elevatori meccanici per la consegna al piano delle lastre. • La movimentazione al piano può essere gestita con l'ausilio di un telaio provvisto di ventose per conferire una maggiore stabilità alla lastra. • Eventualmente si possono utilizzare apposite ventose idonee per la movimentazione manuale. • Per spostamenti in ampie superfici è anche possibile utilizzare un carrello per il trasporto delle lastre.

When unpacking the slabs, for safety reason, it is necessary to alternate sides when removing the slabs from the frame – first one side, then from the other. This will maintain and ensure greater stability. Where possible, mechanical lifting systems should be used for delivering slabs above the ground floor. • Handling the slabs on the floor can be managed with the aid of a frame fitted with suction cups to make the slabs more stable. • The appropriate suction cups may be used for manual handling. • For moving the slabs over large surfaces, a forklift can be used.



## POSA LAYING

È fondamentale verificare la planarità, la differenza massima consentita è di 1 mm ogni 2 metri. • Si raccomanda l'applicazione della colla con doppia spalmatura. La prima, sulla lastra da posare, deve essere applicata al lato corto. Mentre la seconda, nella stessa direzione, deve essere applicata al massetto. • Per evitare che le lastre si scheggino durante la fase di posa si consiglia l'uso di un apposito dispositivo per l'accostamento delle lastre. • È necessario l'utilizzo di sistemi di livellatura per rendere perfetta la planarità della superficie posata. • Una volta adagiata la lastra, per eliminare completamente eccessi di aria, è necessario effettuare una battitura, manuale o meccanica, con l'apposito frattazzo anti-rimbalzo, procedendo dal centro verso i lati esterni.

It is essential to check warpage; the maximum tolerance permitted is 1 mm every 2 metres. • A double layer of glue is recommended. The first, on the slab to be laid, must be parallel to the short side, while the second must be applied to the base, and spread in the same direction. • To avoid the slabs being chipped during laying, an appropriate device should be used for placing the slabs next to one another. • Levelling systems are recommended to ensure the surface laid is perfectly level. • Once the slab is in position, excess air should be removed completely by tapping it either manually or mechanically using the appropriate trowel, starting from the centre and moving out towards the sides.



## STUCCATURA GROUTING

Prima di realizzare le fughe, attendere fino alla completa asciugatura del collante.

### Istruzioni:

1. Assicurarsi che i giunti di posa siano vuoti e liberi da ogni traccia di collante e/o polveri.
2. Stuccare piccole superfici per volta (4-5 mq) in particolare se si tratta di prodotti strutturati, antiscivolo e levigati, utilizzando apposite spatole in gomma.
3. Eliminare l'eccesso di fugante dalla superficie quando il prodotto è ancora umido, e togliere tutti i residui.
4. Pulire accuratamente con una spugna bagnata in acqua pulita e ripassare con uno straccio umido su tutta la superficie, comprese le fughe.

Wait until the glue has completed dried before grouting.

### Instructions:

1. Ensure that the joints are empty and free from any trace of adhesive and/or dust.
2. Grout small surfaces at a time (4-5 sqm) especially if it is structured, non-slip and polished products, using special rubber spatulas.
3. Remove excess fugant from the surface when the product is still wet, and remove all residues.
4. Clean thoroughly with a sponge soaked in clean water and wipe with a damp cloth over the entire surface, including the joints.

## TAGLIO CUTTING

Si raccomanda di effettuare le operazioni di taglio sopra ad un piano perfettamente stabile e planare. • Si consiglia l'utilizzo di una guida di taglio provvista di utensile con la punta diamantata. • Per ottenere il taglio, evitando la rottura del materiale, si consiglia l'utilizzo di apposite pinze troncatrici. • È consigliato anche il taglio delle lastre tramite sega a secco oppure ad acqua con disco diamantato. • Per tagli a L o interni alla lastra si raccomanda la realizzazione di fori in corrispondenza dei vertici per evitare che la superficie si danneggi con la lama del flessibile. • Per realizzare fori circolari sulle lastre si raccomanda di utilizzare una fresa diamantata con il diametro desiderato e di bagnare costantemente al superficie. Cutting operations should be carried out on a perfectly stable, flat surface.

• A cutting guide fitted with a diamond tip tool is recommended. • To cut the slab without breaking the material, the appropriate shears should be used. • The slabs can also be cut with a dry saw or wet saw with a diamond wheel cutter. • For L-shaped cuts or cuts inside the slab, holes should be bored at the vertices to prevent the blade of the cutting disk damaging the surface. • To bore cylindrical holes on the slabs, a diamond cutting tool of the desired diameter should be used, and the surface should be kept wet constantly.

## PARAMETRI PARAMETERS

### Velocità di avanzamento Feed rate

1) Rispettare tutte le norme e le precauzioni alla base di una corretta esecuzione del lavoro: preparazione del sottofondo, composizione della malta o dei collanti, rispetto dei tempi di essiccazione, posizionamento dei giunti di dilatazione, battitura, ecc.

- Minore è il diametro del disco, maggiore è la velocità di rotazione al mandrino.
- Minore è la velocità di avanzamento, maggiore è la qualità del taglio.
- Una minore velocità di avanzamento permette di realizzare una bisellatura ridotta del bordo.
- La velocità di ingresso e di uscita devono sempre essere ridotte del 50% rispetto la velocità di regime.
- Orientamento corretto e quantità di acqua.
- La parte più esposta del disco deve essere ridotta il più possibile, considerando almeno 1mm circa di trapasso oltre lo spessore della lastra.
- La lavorazione avviene con successo se le vibrazioni dovute al taglio sono ridotte al minimo. Per limitare tali vibrazioni è consigliabile mettere sotto la lastra un pannello di legno o di gomma.

2) La posa deve essere effettuata da personale qualificato e con attrezzi adeguati.

La scelta dell'adesivo dipende dalla tipologia delle piastrelle (gruppo di appartenenza e formato), dalla superficie da rivestire e dalla sua destinazione d'uso. Verificare la posa del materiale prima che il collante sia secco, per facilitare eventuali correzioni.

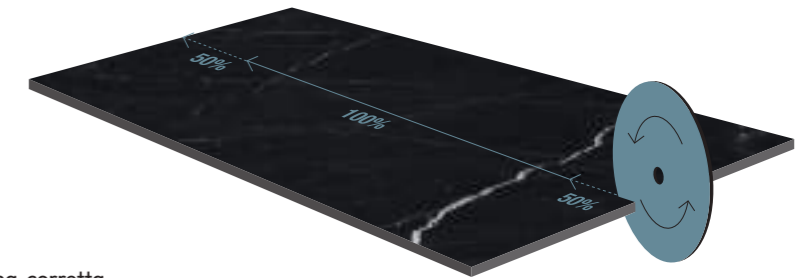

1) Comply with all the rules and precautions required for the correct execution of the work: preparation of the substrate, composition of the mortar or adhesives, compliance with drying times, positioning of expansion joints, beating, etc.

- The smaller the disc diameter, the greater the spindle rotation speed.
- The lower the feed speed, the greater the cutting quality.
- A lower feed speed ensures finishing with reduced chamfer on the edge.
- The infeed and outfeed must always be 50% less than nominal working speed.
- Correct positioning and amount of water.
- As little of the disc as possible must be exposed, considering at least 1mm passing beyond the thickness of the slab.
- Successful machining will be ensured if the vibrations emitted by the cutting operations are reduced to a minimum. To limit the vibrations, place a disposable wooden or rubber-based panel under the slab.

2) The installation must be carried out by qualified personnel and with appropriate tools.

The choice of adhesive depends on the type of tiles (group of belonging and size), the surface to be covered and its intended use. Check the laying of the material before the glue is dry, to facilitate any corrections.

## SISTEMA DI IMBALLAGGIO PACKAGING SYSTEM

120x278 - 120x120 - 60x120

Consigliamo sempre per ogni cavalletto e per ogni cassa di imballare una sola tipologia di formato. Se necessario, è possibile imballare differenti tipologie di formati, purché siano modulari e assicurandosi di collocare alla base quelli di maggiori dimensioni e di evitare il loro movimento interno. È opportuno spedire i cavalletti in condizioni di pieno carico. Nel caso di trasporto delle lastre via container, è vivamente raccomandato l'utilizzo del cavalletto.

We always recommend for each A-frame and for each crate to pack a single type of size. If necessary, it is possible to pack different types of sizes, as long as they are modular and making sure to place the larger ones at the base and avoid their internal movement. The racks should be shipped in full load condition. In the case of transport of slabs by container, it is highly recommended to use the A-frame

Lastre 120x278 Cavalletto (Pz sfusi) dimensioni cm 75 x 290 x 160h — Mq lastra 3,34 — Kg lastra 51,44  
Lastre per cavalletto 40 — Mq per cavalletto 133,60 — Kg cavalletto pieno 2.200,00  
Cassa per lastre 120x278 Cassa in legno (Pz sfusi) dimensioni cm 137 x 292 x 42h — Mq lastra 3,34 — Kg lastra 51,44  
Lastre per cassa 20 — Mq per cassa 66,80 — Kg cassa piena 1170,00



Durante la sovrapposizione delle casse, avere cura di centrare esattamente la rosetta della cassa sottostante.  
When stacking the crates, take care to center the hooking system of the underlying crate exactly

## MOVIMENTAZIONE DEGLI IMBALLI PACKAGING HANDLING

Aprire le forche fino alla massima apertura possibile ed inforcare nel centro esatto degli imballi.

Open the forks until they open as wide as possible and place in the exact centre of the packages.

### Lato lungo

È l'opzione più indicata. Usare forche lunghe almeno 1,4 m allargate al massimo per coprire il più possibile la superficie dell'imballo.

### Long side

This is the best option. Use forks at least 1.4 m in length, enlarged to the maximum to cover as much as possible the surface of the packaging.

### Lato corto

Usare forche lunghe almeno 2,3 m allargate al massimo per coprire il più possibile la superficie dell'imballo.

### Short side

Use forks at least 2,3 m in length enlarged to cover as much as possible the surface of the packaging

### CARICO CAMION E CONTAINER

Per caricare gli imballi nei container si possono usare carrelli elevatori oppure è possibile caricare da terra, con l'aiuto di rampe su misura. Per assicurare il materiale durante il trasporto si raccomanda l'uso di cinghie, tiranti e airbag. Durante il carico assicurarsi sempre che il peso sia distribuito per evitare sbilanciamenti durante la movimentazione. Il calcolo per il riempimento deve sempre tenere conto dei limiti di peso per il trasporto.

### LOADING TRUCKS AND CONTAINERS

Forklifts can be used to load packages into containers, or they can be loaded from the ground with the help of custom ramps. The use of straps, tie rods and airbags is recommended to secure the material during transport. During loading always ensure that the weight is distributed to avoid imbalances during handling. The calculation for filling must always take into account the weight limits for transport.



Movimentare gli imballi con cura, uno alla volta, mantenere una velocità ridotta e solamente lungo un percorso pianeggiante.

Handle the packages carefully, one at a time, maintain a reduced speed and only along a flat path.

### DISPOSIZIONE PER CARICO SU CONTAINER

size 120x278cm  $\frac{1}{2}$  6,5 mm  
CONTAINER 20': 10 CRATES — 6 A-FRAME  
CONTAINER 40': 20 CRATES — 12 A-FRAME  
Mixed crates / A-frame  
CONTAINER 20': 10 CRATES — 2 A-FRAME  
size 120x120cm  $\frac{1}{2}$  6,5 mm — 9 mm — 20 mm  
CONTAINER 20': 12 PALLET  
CONTAINER 40': 24 PALLET  
size 60x120cm  $\frac{1}{2}$  6,5 mm — 9 mm — 20 mm  
CONTAINER 20': 36 PALLET  
CONTAINER 40': 72 PALLET  
FARE ATTENZIONE AL PESO LORDO MASSIMO

### ARRANGEMENT FOR LOADING ON CONTAINERS

size 120x278cm  $\frac{1}{2}$  6,5 mm  
CONTAINER 20': 10 CRATES — 6 A-FRAME  
CONTAINER 40': 20 CRATES — 12 A-FRAME  
Mixed crates / A-frame  
CONTAINER 20': 10 CRATES — 2 A-FRAME  
size 120x120cm  $\frac{1}{2}$  6,5 mm — 9 mm — 20 mm  
CONTAINER 20': 12 PALLET  
CONTAINER 40': 24 PALLET  
size 60x120cm  $\frac{1}{2}$  6,5 mm — 9 mm — 20 mm  
CONTAINER 20': 36 PALLET  
CONTAINER 40': 72 PALLET  
PAY ATTENTION TO THE MAXIMUM GROSS WEIGHT

## CONTAINER

120x278 - 120x120 - 60x120



CONTAINER 20' BOX	
Inside Dimensions	
Length in mm	5860
Width in mm	2310
Height in mm	2260-2360
Tare in Kgs	2050-2650
Max gross weight in Kgs	18270-27980

CONTAINER 40' BOX	
Inside Dimensions	
Length in mm	12010
Width in mm	2290-2300
Height in mm	2260-2360
Tare in Kgs	3630-3740
Max gross weight in Kgs	26740-26850

### CONTAINER 20' BOX SLAB 120x278



75x290x160 H 1A FRAME	75x290x160 H 1A FRAME
75x290x160 H 1A FRAME	75x290x160 H 1A FRAME
75x290x160 H 1A FRAME	75x290x160 H 1A FRAME



SLABS 137x292x42 H 5 CRATES	75x290x160 H 1A FRAME
75x290x160 H 1A FRAME	SLABS 137x292x42 H 5 CRATES

### CONTAINER 40' BOX SLAB 120x278



SLABS 137x292x42 H 5 CRATES		SLABS 137x292x42 H 5 CRATES	
	SLABS 137x292x42 H 5 CRATES		SLABS 137x292x42 H 5 CRATES





75x290x160 H 1A FRAME	75x290x160 H 1A FRAME	75x290x160 H 1A FRAME	75x290x160 H 1A FRAME
75x290x160 H 1A FRAME	75x290x160 H 1A FRAME	75x290x160 H 1A FRAME	75x290x160 H 1A FRAME
75x290x160 H 1A FRAME	75x290x160 H 1A FRAME	75x290x160 H 1A FRAME	75x290x160 H 1A FRAME

# IMBALLI PACKAGING

## 120x278 - 120x120 - 60x120

160x320 cm   63"x126" in				CASSA CRATE			CAVALLETTO A-FRAME			
Spessore Thickness	U.M	LASTRA SLAB	kg / LASTRA KG / SLAB	LASTRE / cassa SLABS / crate	mq / cassa SQM / crate	kg / cassa KG / crate	LASTRE / cav. SLABS / a-frame	mq / cav. SQM / a-frame	kg / cav. LEGNO KG / WOOD a-frame	kg / cav. metallo KG / metal a-frame
6,5 mm / 0.25"	Mq <sup>2</sup> Sf <sup>2</sup>	5,12 55,11	76,8	15	76,80	1.275	44	255,28	3.619,20	3.509,20
12 mm / 0.47"	Mq <sup>2</sup> Sf <sup>2</sup>	5,12 55,11	152,00	9 (Lev./Honed) 10 (Matt)	46,08 (Lev./Honed) 51,20 (Matt)	1.519,00 (Lev./Honed) 1.671,00 (Matt)	24	122,88	3.803,00	3.903,00
2 cm / 0.78"	Mq <sup>2</sup> Sf <sup>2</sup>	5,12 55,11	256	5	25,60	1.395	14	71,68	3.824,00	3.714,00

Wood A-Frame: 350,00€  
Steel A-Frame: 450,00€  
Crate: 150,00€

formato size	spessore thickness	imballo packaging	pz/scat pcs/box	mq/scat m <sup>2</sup> /box	kg/mq kg/sqm	scat/imb box/pack	pz totali pcs total	mq totali sqm total	kg/imb kg/pack	kg totali kg total	€
120x278	6,5	cassa/crate			15,40		20	66,80	149,00	1170,00	L 292 H 42 P 137  145,00
		cassa/crate			15,40		da 1 a 10 pz		125,00		130,00
		cavalletto A-frame			15,40		40	133,60	150,00	2001,00	L 290 H 10 P 137  280,00
					<b>kg/scat kg/box</b>						
120x120	9	pallet con sponde pallet with sides	2	2,88	56,45	21	42	60,48	40,00	1225,45	L 143 H 50 P 123  42,00
	20	pallet	1	1,44	67,25	16	16	23,04		1116,00	
60x120	9	pallet	2	1,44	28,25	30	60	43,20	20,00	867,50	
	20	pallet	1	0,72	33,62	32	32	23,04		1095,84	

I DATI RELATIVI AGLI IMBALLI E AI PESI POSSONO SUBIRE DELLE VARIAZIONI  
INFORMATIONS AND DETAILS RELATED TO PACKAGING AND WEIGHT ARE SUBJECT TO CHANGE

# CERTIFICAZIONI CERTIFICATIONS



# IMBALLI PACKAGING

## 160x320

Le lastre Nuovocorso possono essere fornite sia in cassa che su cavalletto.  
Nuovocorso slabs can be packed in crate or on A-Frame

### CASSA CRATE

FORMATO SIZE > 345x175x37 cm 136"x69"x14"

PESO VUOTA EMPTY WEIGHT > 120 KG

ADDEBITO CHARGE > 150€ CAD/EACH

### CAVALLETTO IN LEGNO WOOD A-FRAME

CAVALLETTO A-FRAME > 330x75x200 cm 130"x30"x79"

PESO VUOTO EMPTY WEIGHT > 240 KG

ADDEBITO CHARGE > 350€CAD/EACH

### CAVALLETTO IN METALLO METAL A-FRAME

CAVALLETTO A-FRAME > 330x75x200 cm 130"x30"x79"

PESO VUOTO EMPTY WEIGHT > 130 KG

ADDEBITO CHARGE > 450€CAD/EACH

				CASSA CRATE			CAVALLETTO A-FRAME			
SPESSORE THICKNESS	U.M	LASTRA SLAB	KG / LASTRA KG / SLAB	LASTRE / CASSA SLABS / CRATE	MQ / CASSA SQM / CRATE	KG / CASSA KG / CRATE	LASTRE / CAV. SLABS / A-FRAME	MQ / CAV. SQM / A-FRAME	KG / CAV. LEGNO KG / WOOD A-FRAME	KG / CAV. METALLO KG / METAL A-FRAME
6,5 mm / 0.25"	Mq <sup>2</sup> Sf <sup>2</sup>	5,12 55,11	76,8	15	76,80	1.275	44	255,28	3.619,20	3.509,20
12 mm / 0.47"	Mq <sup>2</sup> Sf <sup>2</sup>	5,12 55,11	148,48	9 (Lev./Honed) 10 (Matt)	46,08 (Lev./Honed) 51,20 (Matt)	1.488 (Lev./Honed) 1.640 (Matt)	24	122,88	3.803,52	3.693,20
2 cm / 0.78"	Mq <sup>2</sup> Sf <sup>2</sup>	5,12 55,11	256	5	25,60	1.395	12	61,44	3.312,00	3.202,00

### INFORMAZIONI CONTAINER 20FT' A-FRAME INFORMATIONS CONTAINER 20FT' A-FRAMES

	U.M	SPESSORE 6.5MM THICKNESS 6.5MM	SPESSORE 12MM THICKNESS 12MM	SPESSORE 20MM THICKNESS 20 MM
CAVALLETTI X CONTAINER / A-FRAME X CONTAINER	PZ/PCS	3	3	3
PZ X CONTAINER / PCS X CONTAINER	PZ/PCS	132	72	36
PESO LORDO TOTALE / GROSS WEIGHT	Kg	10,137	10,690	9,216
MQ2 TOTALI / TOTAL SM2	Mq2	675,84	368,64	184,32

### INFORMAZIONI CONTAINER 20FT' BUNDLES INFORMATIONS CONTAINER 20FT' BUNDLES

	U.M	SPESSORE 6.5MM THICKNESS 6.5MM	SPESSORE 12MM THICKNESS 12MM	SPESSORE 20MM THICKNESS 20 MM
BUNDLES X CONTAINER / BUNDLES X CONTAINER	PZ/PCS	8	8	8
PZ X CONTAINER / PCS X CONTAINER	PZ/PCS	144	96	
PESO LORDO TOTALE / GROSS WEIGHT	Kg	21,381	24,576	
MQ2 TOTALI / TOTAL SM2	Mq2	737,28	491,52	

### INFORMAZIONI CONTAINER 40FT' A-FRAME INFORMATIONS CONTAINER 40FT' A-FRAME

	U.M	SPESSORE 6.5MM THICKNESS 6.5MM	SPESSORE 12MM THICKNESS 12MM	SPESSORE 20MM THICKNESS 20 MM
CAVALLETTI X CONTAINER / A-FRAME X CONTAINER	PZ/PCS	25 TON - 6 27 TON - 7	25 TON - 6 27 TON - 7	25 TON - 6 27 TON - 7
PZ X CONTAINER / PCS X CONTAINER	PZ/PCS	264 308	144 168	72 84
PESO LORDO TOTALE / GROSS WEIGHT	Kg	20.275 23.654	21.381 24.944	18.432 21.504
MQ2 TOTALI / TOTAL SM2	Mq2	1.351.68 1.576.96	737.28 860.16	430.08 501.76



## PULIZIA E NORME DI MANUTENZIONE

### CLEANING PRODUCTS AND MAINTENANCE INSTRUCTIONS

Un pavimento o una parete rivestiti con prodotto ceramico rappresentano sicuramente superfici altamente resistenti all'usura e alle macchie, la cui durata è comunque soggetta al modo in cui vengono usate e mantenute. È sufficiente a tal fine osservare alcune semplici precauzioni, dettate principalmente dal buon senso e dalla conoscenza delle caratteristiche dei materiali.

Prodotti per la pulizia.

Quello che vediamo della superficie piastrellata è costituito da prodotto ceramico e da fughe, di entrambi i quali occorre avere cura. Per la pulizia quotidiana, usare acqua e detersivi neutri adatti, quali quelli specifici in commercio. Evitare di utilizzare prodotti acidi o aggressivi (ad esempio, quelli che si impiegano per la pulizia e la disincrostazione dei sanitari), che potrebbero danneggiare i materiali a base di cemento con cui vengono sigillate le fughe e opacizzare la superficie dei materiali lucidi, levigati o lappati.

Metodi di pulizia.

Per le operazioni di pulizia, limitare a casi di estrema necessità l'uso di strumenti e/o detersivi abrasivi (quali la paglietta di metallo). Evitarne assolutamente l'uso su piastrelle con superficie lucida, più esposte alla visibilità di graffi, scalfitture e opacizzazioni.

Sporco abrasivo.

Si consiglia di prevenire il più possibile la presenza sul pavimento di polvere e sabbia trasportati dall'esterno, poiché aumentano l'effetto abrasivo del traffico pedonale. È sufficiente predisporre uno stuoio all'ingresso dell'abitazione e mantenere il pavimento più pulito possibile.

Prodotti con superficie strutturata.

Le piastrelle con superficie strutturata, i mosaici e i decori a rilievo presentano eccellenti caratteristiche di sicurezza (resistenza allo scivolamento), ma necessitano di particolare cura nella pulizia per eliminare accumuli di sporcizia nelle asperità della superficie. Nella pulizia ordinaria si può utilizzare un normale detersivo neutro, avendo però cura di strofinare in due direzioni: prima seguendo l'orientamento della struttura, poi procedendo trasversalmente.

#### IMPORTANTE

1. Si consiglia la massima prudenza nell'uso dei prodotti chimici, seguire attentamente le istruzioni d'uso previste per ogni prodotto.
2. Ogni applicazione di detersivi, acidi o solventi deve essere seguita da abbondante risciacquo e accurata asciugatura.
3. Non usare mai sostanze contenenti Acido Fluoridrico. Vi ricordiamo che smacchiatori spray e antiruggine spesso contengono Acido Fluoridrico.
4. Prima dell'utilizzo di prodotti per la pulizia, in particolare di quelli a base acida, effettuare una prova su una piccola porzione nascosta della superficie da trattare.

Tipo di sporco Type of stain	Indicazioni per la pulizia Cleaning suggestions
Grassi animali o vegetali • Caffè • Coca cola • gelato • salsa ketchup Vegetable and animal fat • Coffee • Coke • Ice cream • Ketchup	Detersivi a base alcalina Alkaline-based detergent
Depositi • Effluorescenze calcaree • Inchiostri • Ruggine e depositi ferrosi Deposits • Calcareous efflorescences matter • Ink • Rust and Oxidations	Detersivo a base acida* Acid-based detergents*
Olii di parti meccaniche • Gomma da pneumatico • Resine o smalti • Cera di candela • Grafite (matita) Grease from machines • Tyre rubber • Paints • Candle wax • Graphite (pencil)	Solvente Solvent
Birra • Vino • Piombatura da levigatura Beer • Wine • Lead finishing of the polish process	Detersivi a base alcalina • Detersivo a base acida* Alkaline-based detergent • Acid-based detergents*
Lampostil Felt tipped pen	Solvente • Detersivo a base acida* Solvent • Acid-based detergent*
Olio di lino Linseed oil	Detersivi a base alcalina • Solvente Alkaline-based detergent • Solvent
Pulizia quotidiana Daily cleaning	Acqua e detersivi neutri Water and neutral detergents

Floors or walls tiled are extremely resistant to wear and stains. However, the effective durability of the surface depends on how it is used and maintained.

To ensure extended durability, simply follow a few basic precautions, based on common sense and an understanding of the properties of the materials themselves.

Cleaning products.

The exposed side of a tiled surface consists of the ceramic product itself and grout joints. Both components require special care. For everyday cleaning, use water and appropriate neutral detergents commonly found at supermarkets.

Do not use acid or corrosive products (such as those used to remove limescale

from kitchen and bathroom sanitary-ware). These may damage the cement based materials used to fill the grout joints and dull the surface of polished, honed and polished

materials.

Cleaning methods.

When cleaning, use abrasive products (such as steel wool) and abrasive detergents as little as possible. Never use these products on tiles with polished surfaces, as these are more susceptible to visible scratching and scoring and are more likely to become dull.

Abrasive dirt.

Where possible, keep the floor free of dust and sand carried in from outside, as these increase the abrasive effect of foot traffic. Simply place a doormat at the entrance to your home and keep the floor as clean as possible.

Products with textured surfaces.

Tiles with structured surfaces, mosaics and relief decorations have excellent safety qualities (slip resistance), but require greater care during cleaning to remove the dirt that accumulates in the irregularities in the surface. For regular cleaning, use a normal neutral detergent, wiping both lengthwise and crosswise to remove all dirt.













#### IMPORTANT

1. Use chemical products with extreme caution. Follow carefully the specific instructions for each product.
2. Always rinse and wipe dry thoroughly after using any detergent, acid or solvent.
3. Never use products containing fluorhydric acid. Stain remover and rust remover sprays often contain fluorhydric acid.
4. Before using any cleaning product, especially acidic products, test on a small concealed areas of the surface to be treated beforehand.

## CARATTERISTICHE TECNICHE

### TECHNICAL FEATURES

Gres Porcellanato Rettificato - Rectified Porcelain Stoneware

CARATTERISTICHE TECNICHE PHYSICAL PROPERTIES	NORME NORMS	VALORE PRESCRITTO DALLE NORME REQUIRED STANDARDS	VALORE ITALSLAB ITALSLAB VALUES	
 <b>Dimensione media di ogni piastrella</b> Length and width of the average sizes tiles	10545-2	+0,5	CONFORME	
 <b>Assorbimento d'acqua</b> Water absorption	ISO 10545-3	≤ 0,5%	<b>Conforme</b> Comply with	
 <b>Resistenza alla flessione</b> Bending strength	ISO 10545-4	<b>Spessore / Thickness &gt; 7,5 mm</b> <b>Modulo di rottura &gt; 1300 N</b> Breaking resistance > 35 N/mm <sup>2</sup> Module of ropture > 1300 N <b>Sforzo di rottura &gt; 35 N/mm<sup>2</sup></b>	<b>Spessore / Thickness &lt; 7,5 mm</b> <b>Modulo di rottura &gt; 700 N</b> Breaking resistance > 32 N/mm <sup>2</sup> Module of ropture > 700 N <b>Sforzo di rottura &gt; 32 N/mm<sup>2</sup></b>	<b>Conforme</b> Comply with
 <b>Resistenza all'abrasione profonda</b> abrasion deep resistance	ISO-10545-6	minore di 175mm <sup>2</sup> (volume asportato-volume removed)	<b>Conforme</b> Comply with	
 <b>Durezza (Scala Mohs)</b> Hardness (Mohs scale)	(EN 101)	<b>Non in vigore</b> Not in force	<b>Conforme</b> Comply with	
 <b>Coefficiente di dilatazione termica lineare</b> Coefficient of linear thermal expansion	ISO 10545-8	≤ 9x10 <sup>-6</sup> °C <sup>-1</sup>	<b>Conforme</b> Comply with	
 <b>Resistenza agli sbalzi termici</b> Thermal shock resistance	ISO 10545-9	<b>Nessun campione deve presentare difetti visibili</b> No sample must show visible defects	<b>Conforme</b> Comply with	
 <b>Resistenza al gelo</b> Frost resistance	ISO 10545-12	<b>Nessun campione deve presentare rotture o alterazioni apprezzabili della superficie</b> No sample must show breaks or evident alterations of the surface	<b>Conforme</b> Comply with	
 <b>Resistenza all'attacco chimico</b> Chemical resistance	ISO 10545-13	<b>Metodica di prova disponibile</b> Testing method available	<b>Conforme</b> Comply with	
 <b>Resistenza alle macchie</b> Stain resistance	ISO 10545-14	<b>Classe 3 min</b> Minimum class 3	<b>Conforme</b> Comply with	
 <b>Resistenza dei colori alla luce</b> Color resistance to light	DIN 51094	<b>Non devono presentare apprezzabili variazioni di colore</b> No noticeable color change	<b>Campioni inalterati in brillantezza e colore</b> No change in brightness or color	
 <b>Resistenza allo scivolamento</b> Slip resistance	B.C.R.A. ASTM C 1028 ANSI A 137.1 DIN 51130 DIN 51097 AS/NZS 4586 ENV 12633 BS 7976-2	> 0,40 > 0,60 > 0,42 WET 10° < α ≤ 19° = R10 19° < α ≤ 27° = R11 27° < α ≤ 35° = R12 Da 12° a 18° - A Da 18° a 24° - B > 24° - C SRV: 35-44 -	<b>Valore fornito a richiesta</b> Value supplied on demand	

<sup>1</sup> Escluso i prodotti lappati / Polished products are excluded

\* Mohs ≥ 5 Superficie Lappata / Polished surface

Grado di variazione cromatica  
Degree of colour change

**V1** Aspetto uniforme  
Uniform appearance

**V2** Lieve variazione  
Slight appearance

**V3** Moderata variazione  
Moderate appearance

**V4** Forte variazione  
Substantial appearance

**ITAL SLAB**

MADE IN ITALY

